

Analyzing the Proposal to use Robotics to Manually Extend a Multipurpose Agricultural Machine for Indian Farmers

Mohammed Pasha Yousuf, Ch.Naveen, Durgam Sammakka, B.Naresh

^{1,2,3}Assistant Professor, ⁴Student, Dept. of Mechanical Engineering, Brilliant Institute of Engineering and Technology, Hyderabad, Telangana, India

ABSTRACT

India is an agriculture-based country where 70% of the population relies on the results of farming. However, as the population grows, the farm is dispersed among the family, and as a result, the average farmer in India has only a two-acre farm. Farmers are also economically disadvantaged, which prevents them from purchasing tractors and other expensive equipment, forcing them to rely on traditional farming methods. Many Indian farmers rely on bullocks, horses, and he-buffalo for their farming operations. In comparison to other countries in the world, this will not suffice to meet the energy needs of agriculture. As a result, we created a machine that performs numerous tasks utilizing diverse mechanisms in order to make agriculture more cost-effective by reducing manual labor and animal labor for small scale farmers. In this equipment we used pouching rod, water sprayer, seed sowing and leveling attachments. This machine performs the operations like pouching, seed sowing, water spraying and land leveling which is used for small scale farming. As an added advantage this machine is operated with the help of manual drive. By using above attachments, one may perform various farming operations in less time and cost with reduced man power resources.

KEYWORDS

Agriculture machine, ploughing, water sprayer, seed sowing, leveling attachments.

1. INTRODUCTION

Agriculture is the science and art of cultivating plants and livestock. Agriculture was the key development in the rise of sedentary human civilization, whereby farming of domesticated species created food surpluses that enabled people to live in cities. The history of agriculture began thousands of years ago. After gathering wild grains beginning at least 105,000 years ago, nascent farmers began to plant them around 11,500 years ago. Pigs, sheep and cattle were domesticated over 10,000 years ago. Plants were independently cultivated in at least 11 regions of the world. Industrial agriculture based on large-scale monoculture in the twentieth century came to dominate agricultural output, though about 2 billion people still depended on subsistence agriculture into the twenty-first. India is currently the world's second or third largest producer of several dry fruits, agriculture-based textile raw materials, roots and tuber crops, pulses, farmed fish, eggs, coconut, sugarcane and numerous vegetables. India ranked in the world's five largest producers of over 80% of agricultural produce items, including many cash crops such as coffee and cotton, in 2010. India is one of the world's five largest producers of livestock and poultry meat, with one of the fastest growth rates, as of 2011. India has shown a steady average nationwide annual increase in the kilograms produced per hectare for some agricultural items, over the last 60 years. These gains have come mainly from India's green revolution, improving road and power generation infrastructure, knowledge of gains and reforms. Despite these recent accomplishments, agriculture has the potential for major productivity and total output gains, because crop yields in India are still just 30% to 60% of the best sustainable crop yields achievable in the farms of developed and other developing countries. Additionally, losses after harvest due to poor infrastructure and unorganized retail cause India to experience some of the highest food losses in the world.

The idea of robotic agriculture (agricultural environments serviced by smart machines) is not a new one.

Many engineers have developed driverless tractors in the past but they have not been successful as they did not have the ability to embrace the complexity of the real world. Most of them assumed an industrial style of farming where everything was known before hand and the machines could work entirely in predefined ways – much like a production line. The approach is now to develop smarter machines that are intelligent enough to work in an unmodified or semi natural environment [1].

Design and fabrication of this multi-purpose farming tool equipped mobility cycle was done after considering special demand of decreasing cost of cultivation, making cultivation pollution free in our society. So, we designed a vehicle whose motion is based on the cycle concept and its function or application is based on other farming-based tractors or other farm-based machinery. Basically, our designed vehicle can be used for ploughing, seeding, covering soil at same time without consuming any type of fossil fuel [2].

In modern globalization, many technologies are trying to update a new development based on automation which works very rigidly, high effectively and within short period of time period. Now the approach of this project is to develop smart machine which do the right thing at right place at right time with right amount in process of farming. The main goal of this project is the development of the vehicle and the control unit, with possibility of using different sensor technologies. We want to test the vehicle and control unit and show that the robot is capable of following a path under field conditions. Today the environmental impact of agricultural production is very much in focus and the demands to the industry is increasing. The production of agricultural products is growing and the competition is getting bigger, therefore the farmer has to be very efficient to be able to compete. At the same time the demands, for less use of pesticides and fertilizers, from the consumer and the legislation are increasing. Therefore the farmers have to use high technology in the fields for weeding, spraying, etc., earlier weeding were done manually but today it is neither profitable or possible to get a sufficient number of labor for this job. In this project, an autonomous agricultural vehicle, for test and development of sensors, tools and information technology in the field, is going to be developed [3-7].

The idea of applying robotics technology in agriculture is very new. In agriculture, the opportunities for robot-enhanced productivity are immense - and the robots are appearing on farms in various guises and in increasing numbers. We can expect the robots performing agricultural operations autonomously such as ploughing, seed sowing, mud closing and water spraying. Watching the farms day & operations have been identified to be the first potential practical applications: crop establishment, plant care and selective harvesting. The paper aims on the design, development and the fabrication of the robot which can dig the soil, put the seeds, leveler to close the mud and sprayer to spray water, these whole systems of the robot works with the battery and the solar power. More than 40% of the population in the world chooses agriculture as the primary occupation, in recent years the development of the autonomous vehicles in the agriculture has experienced increased interest [8-9].

A segmentation was performed using image intensity, size and geometric information to pick out crop plants requiring treatment. This information was passed to the treatment device controller which selected from an array of 27 solenoid valves to operate appropriate spray nozzles arranged transversely across the machine. Field trials of selective spray treatment of a young transplanted crop, conducted at a vehicle speed of 0.7 m/s, showed that all plants were treated, though coverage of each plant was not perfect. Mean measured error along the row was 1 mm and lateral error 11 mm. The standard deviation in these errors were 26 and 20 mm, respectively. Only 8% of the total area of the bed was covered with spray, thus showing a potentially large saving in agro-chemicals with environmental and economic advantages. The vehicle has been operated extensively in a wide variety of crops of different sizes and ground coverage, with good reliability under favorable lighting conditions [9]. The 21st century is said to be century of creation, progress, globalization and so much else, but the second side too, that is nothing but 21st century is century of the population, global warming, drought and cloud burst also helpless health factors! Automation in agricultural robotics system has been developed to implement a number of agricultural productions in many countries. Such as picking, harvesting monitoring, weeding, seeding, fertilizer, irrigation. But in this project functions included are soil based applications of Seeding, Fertilizer, and Irrigation. The purpose of this project is to design,

minimize the labour of farmers in addition to increasing the speed of the work as well as increase the yield of agriculture. This paper is to develop a robot capable of performing operations like automatic seeding, irrigation, fertilization. It also provides manual as well as auto control. The main component here is the ARDUINO that supervises the entire process. At the present time, robots are increasingly being integrated into working tasks to replace humans especially to perform repetitive task.[10]

2. MODERN FORMING

Modern tools

Modern farming means farming using modern techniques and technology. That means farming with the facilities of modern science and technologies. Using modern science and technologies in farming increase the farming productions. Farming is the cultivation of domestic animals, fish, birds, plants, crop etc. for the purpose of food, cloth and other products essential for sustain life. Farming is playing a vital role in the development of human civilization. Before industrial revolution most of the people labored in farming all over the world. Most of those people used to farming for their family needs of food, cloth etc. They had no target of world marketplace and produce very low due to using traditional farming methods. But now the development of agriculture and farming technology has greatly increased the farming productivity. And the farmers are now able to buy and sell their products in the world markets. In the early 20th century by using synthetic nitrogen with pesticides, mechanization and mined rock phosphate the crop production has greatly increased and it brought green revolution in rice, wheat and corn etc. production. In the past the farmers use plough to dig the soil. But now farmer use modern equipment like multi facilities tractor to dig the soil. In past farmer were dependent on natural condition and fertilizers and produce very low production. But now the farmers use synthetic fertilizers, high productive breeds, pesticides, proper water contamination, mechanization and farm subsidies which greatly increased the farming productivity. The population around the world is increasing rapidly. More people need more products like food, cloth etc. which depends on farming production. So, we need more production in farming which is not possible in traditional farming. So, modern farming is a must to get more production according to rapid population growth.

Modern tools: farming tractors

The farm tractor is used for pulling or pushing agricultural machinery or trailers, for ploughing, tilling, disking, harrowing, planting, and similar tasks. A variety of specialty farm tractors have been developed for particular uses. These include "row crop" tractors with adjustable tread width to allow the tractor to pass down rows of corn, tomatoes or other crops without crushing the plants, "Wheatland" or "standard" tractors with fixed wheels and a lower centre of gravity for ploughing and other heavy field work for broadcast crops, and "high crop" tractors with adjustable tread and increased ground clearance, often used in the cultivation of cotton and other high-growing row crop plant operations, and "utility tractors", typically smaller tractors with a low centre of gravity and short turning radius, used for general purposes around the farmstead. Many utility tractors are used for nonfarm grading, landscape maintenance and excavation purposes, particularly with loaders, backhoes, pallet forks and similar devices. Small garden or tractors designed for suburban and semirural gardening and landscape maintenance also exist in a variety of configurations.

Harvesters

The modern combine harvester, or simply combine, is a versatile machine designed to efficiently harvest a variety of grain crops. The name derives from its combining three separate harvesting operations—reaping, threshing, and winnowing—into a single process. Among the crops harvested this are wheat, oats, rye, barley, corn (maize), sorghum, soybeans, flax (linseed), sun flowers and canola. The separated straw, left lying on the field, comprises the stems and any remaining leaves of the crop with limited nutrients left in it: the straw is then either chopped, spread on the field and ploughed back in or baled for bedding and limited-feed for livestock. Combine harvesters are one of the most economically important labour-saving inventions, significantly reducing the fraction of the population engaged in agriculture.

3. DESIGN AND FABRICATION

The two dimensional model was designed using AUTO CAD. The three dimensional model was designed using SOLID WORKS . The frame, axle, crank and support links

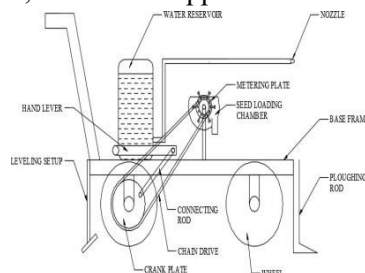

Fig.1: 2D Model of the machine

dimensions were followed like, Length of the main frame= 95 cm, Width of the main frame= 50 cm, Height of the main frame= 35 cm, Diameter of the round rod= 1.5 cm, Diameter of the wheels= 40 cm, Diameter of the seed dispenser =16 cm, Diameter of the crank plate= 16 cm, Capacity of the seed hopper= 500 grams, Capacity of the water tank=10 liters.

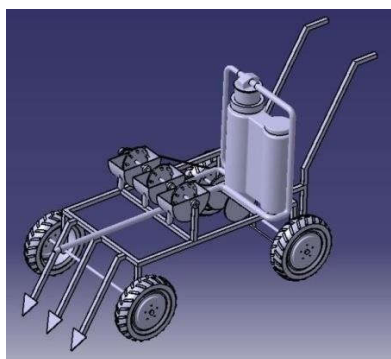

Fig.2: 3D Model of the machine

Frame

The frame is made out of mild steel square rod. Mild steel rod is chosen because its economical and has good endurance. Using high quality materials will definitely increase the life of the machine.

Seed hooper

The seed hopper is fabricated from galvanized iron sheet.

G.I. sheet metal is used to reduce the weight of the machine and fabrication is much easier. Galvanization or galvanizing is the process of applying a protective zinc coating to steel or iron, to prevent rusting.

Chain drive

Alloy steel is used in making chains mostly and they are punched out of steel plates. When a single chain is used it is called a single strand. When three chains are used, it is called a triplex strand. Single strand is used at two places in the machine. One to operate the seed hoppers and the other to rotate the crank plate. On the other hand, the sprockets are made out of cast iron. Cast iron is a group of iron-carbon alloys with a carbon content greater than 2%. [1].

Water tank

A commercial plastic tank is selected because it is portable, weight-less, corrosion free, easy to clean and replace. Plastic is material consisting of any of a wide range of synthetic or semi-synthetic organic compounds that are malleable and so can be molded into solid objects.

Axles

Circular shaft made of mild steel is used for the front and rear axle. Mild steel is the most common form of

steel as its price is relatively low while it provides material properties that are acceptable for many applications. Old motorcycle tyres are reused.

Sprayers

In agriculture, a sprayer is a piece of equipment that is used to apply herbicides, pesticides, and fertilizers on agricultural crops. Sprayers range in size from man-portable units (typically backpacks with spray guns) to trailed sprayers that are connected to a tractor, to self-propelled units similar to tractors, with boom mounts of 60–151 feet in length. A spray nozzle is a precision device that facilitates dispersion of liquid into a spray.

Leveling plates

The leveling equipment is a mild steel plate bolted to the back of the machine. It is used to level the field and remove unwanted soil from the field.

4. WORKING PROCESS

This machine is manually operated and the energy used to operate this machine is converted into the desired work. On pushing the machine, the ploughing rods get in contact with the surface of the agriculture land and it ploughs the land. When this process takes place, simultaneously the chain drive makes the seed sowing unit to function and the seeds are loaded into the mini conveyers and then pushed into the rods which then finally fall on the ploughed field. The leveler then covers the seeds and then pushes away excess soil and unwanted stuff off the field. Finally, with the help of a crank mechanism, water is sprayed. The added advantage is that multiple seeds can be sown at the same time which makes the tiring work simpler and more economical.



Fig.3: Fabricated agriculture machine

This multipurpose agriculture machine has several advantages like, Affordable machine for small scale farmers, User friendly and easy to operate, Man and animal power is reduced. Multiple operations are performed simultaneously, Unwanted and extra soil can be removed using the leveler. Multiple seeds can be sowed at the same time, Since a water sprayer is used, less water is consumed during the process.

CONCLUSION

India is one of the many countries that depend on agriculture to feed its population and there are not many large-scale farmers. Farmers must be educated and updated with the latest technology and this is a great field to bring in advancements. There are countless ways to fabricate this machine and they could be changed according to individual farmer's need. With improvement in the technology in the future, these machines can be made more economical and more user friendly and more autonomous. Robotics is the future in every field there is and it is going to play a major role in the agricultural fields.

After the fabrication and testing of "Manually Operated Multi-Purpose Agriculture Machine" the following conclusions are made:

The machine is very efficient and economical and would be of great use to small scale farmers who cannot afford costly equipment.

Less labor is needed when compared to traditional a method which requires both man and animal labor.

The machine is easy to fabricate when compared to the high-end machines that cost a fortune. As a result, using this machine in small scale farms is highly advantageous both in labor and cost.

REFERENCES

1. Simon Blackmore, Bill Stout, Maohua Wang, Boris Runov (2005), Robotic agriculture – The future of agriculture mechanism, Agro Technology, the royal veterinary and agriculture University. Pp. 21 - 23
2. R. Eaton, R. Eaton, J. Katupitiya, S.D.Pathirana (2008), Autonomous farming: Modeling and control of agricultural machinery in a unified framework, 15th International conference on mechatronics and machine vision in practice, New Zealand. pp. 101- 103
3. Shrinivas R. Zanwar, R.D. Kokate (June 2012), Advanced Agriculture System International Journal of Robotics and Automation (IJRA) magazine, pp. 81-84
4. Blackmore, S. (2007). A system view of agricultural robotics. Precision Agriculture conference, Wageningen Academic Publishers, the Netherlands. pp. 23-31
5. Tillett, N.D., Hague, T. and Marchant, J.A. (1998) A robotic system for plant scale husbandry. Journal of Agricultural Engineering Research, 69, 169-178.
6. Fang-Ming Zhang, Beom-Soo Shin, Xi-Ming Feng, Yuan Li (2013), Development of a prototype of guidance system for rice- transplanter,
7. Journal of Agricultural Engineering Research, pp 212- 215
8. Tyler Troyer (2017), Event and time-triggered control module layers for individual robot control architectures of unmanned agricultural ground vehicles, Journal of Agricultural Research, pp 75-79
9. Ms. Aditi D. Kokate, Prof. Priyanka D.Yadav (2012), Multipurpose agricultural robot, Journal of Agricultural Research, pp 44-47
10. Shubham Dhage, Pradip Patel, Data Kande, Dr. Prakash Patil (2018),
11. Wireless Controlled Multipurpose Agricultural Robot, pp 92-95
12. Design of Machine Element, Prof. V.B. Bhandari, Tata Mc- GrawHill Publishing Company Ltd. 2007 Edition.
13. Design data book, PSG Institutions by Kalaikathir Achchagam
14. Machine design by Robert L and Norton
15. Theory of machines by SS. RATTAN
16. Introduction to Robotics: Mechanics and Control by John J. Craig.
17. Automatic Control Systems, by Benjamin C.Kuo Farid Golnaraghi.