

Integration of LSTM and Recurrent Neural Networks for the Prediction of Steelworker Dyslipidemic Risk

Y.Susheela, Dr.T.Ravi Kumar, Dr.M.Srinivas, Sunkari Dhanasri

^{1,2,3}Associate Professor, ⁴UG Student, ^{1,2,3,4}Department of Computer Science Engineering, Vaageswari College of Engineering, Karimnagar, Telangana, India

ABSTRACT

As medical digitalization, artificial intelligence, and big data technologies improve, the medical paradigm is increasingly changing from one that is treatment-oriented to one that is prevention-oriented. The development of artificial neural networks, in particular deep learning, has led to significant advancements in text processing, natural language processing, picture classification, and other fields in recent years. Using artificial intelligence and big data technologies for illness risk prediction is a research emphasis in the field of intelligent medicine. Blood lipids are one of the main risk factors for cardiovascular and cerebrovascular diseases. Early intervention may be carried out to preserve the health of iron and steel workers if abnormal blood lipids in such employees can be expected. This essay examines the variables that affect steelworkers' dyslipidemia and explains the often used method for disease prediction, and then studies deep learning related theory. This paper introduces the two deep learning algorithms of RNN (Recurrent Neural Network) and LSTM (Latent Semantic Transformation Machine) (Long Short-Term Memory).

INTRODUCTION

These the transition of China's economy from one based on agriculture to one based on industry has been greatly aided by the iron and steel sector, which serves as the foundation of the secondary sector. Even clearer is the role that front-line steel workers play in the manufacture and processing of steel. As a result, the financial gains of each steel production unit, the whole city's revenue, and the overall might of the nation are all intimately correlated with the physical well-being of front-line steel workers [1]. The working conditions for steel employees have substantially improved along with society's and technology's advancements, eventually shifting from manual to machine labour [2]. However, there are still some jobs that require workers to be under high temperature conditions and pay attention for a long time to ensure the successful completion of production work, such as the temperature control of molten iron in front of the furnace, the casting machine, etc., and also require workers to concentrate on standing or sitting for a long time in high temperature and noise. Hence, in addition to occupational diseases, there are also a series of chronic non-infectious diseases in the course of work [3], [4].

Dyslipidemia is one of the major risk factors for a variety of chronic non-infectious diseases, and a major cause of stroke and heart disease [5]. A series of physiological reactions will occur in the human body during high-temperature operation, mainly including changes in body temperature regulation, water and salt metabolism, circulatory system, neuroendocrine system, and urinary system. The mechanism of noise on blood lipids and glucose is not very clear, but there are reports suggesting that noise stimulation can not only damage hearing, but also be introduced into the cerebral cortex and autonomic nervous center through hearing, triggering a series of reactions in the central nervous system.

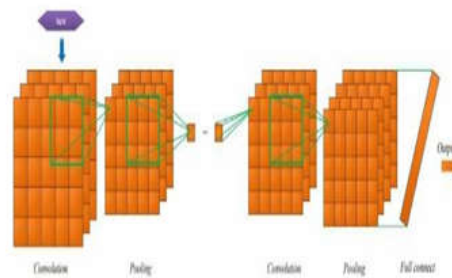

Figure.1: Structure of CNN prediction model for dyslipidemia in steel workers

RELATED WORK

Measurement of chlorine concentration on steel surfaces via fiber-optic laser-induced breakdown spectroscopy in double-pulse configuration:

The corrosive environment provided by chlorine ions on the welds of stainless steel dry cask storage canisters for used nuclear fuel may contribute to the occurrence of stress corrosion cracking. We demonstrate the use of fiber-optic laser-induced breakdown spectroscopy (FOLIBS) in the double-pulse (DP) configuration for high-sensitivity, remote measurement of the surface concentrations of chlorine compatible in constrained space and challenging environment characteristic for dry cask storage systems. Chlorine surface concentrations as low as 5 mg/m² have been detected and quantified by use of a laboratory-based and a fieldable DP FOLIBS setup with the calibration curve approach. The compact final optics assembly in the fieldable setup is interfaced via two 25-m long optical fibers for high-power laser pulse delivery and plasma emission collection and can be readily integrated into a multi-sensor robotic delivery system for in-situ inspection of dry cask storage systems.

Comprehensive genotyping in dyslipidemia: Mendelian dyslipidemias caused by rare variants and mendelian randomization studies using common variants:

Dyslipidemias, especially hyper-low-density lipoprotein cholesterolemia and hypertriglyceridemia, are important causal risk factors for coronary artery disease. Comprehensive genotyping using the „next-generation sequencing“ technique has facilitated the investigation of Mendelian dyslipidemias, in addition to Mendelian randomization studies using common genetic variants associated with plasma lipids and coronary artery disease. The beneficial effects of low-density lipoprotein cholesterol-lowering therapies on coronary artery disease have been verified by many randomized controlled trials over the years, and subsequent genetic studies have supported these findings. More recently, Mendelian randomization studies have preceded randomized controlled trials. When the on-target/off-target effects of rare variants and common variants exhibit the same direction, novel drugs targeting molecules identified by investigations of rare Mendelian lipid disorders could be promising. Such a strategy could aid in the search for drug discovery seeds other than those for dyslipidemias. Risk assessment of hypertension in steel workers based on LVQ and Fisher-SVM deep excavation:

The steel industry is one of the pillar industries in China. The physical and mental health of steel workers is related to the development of China's steel industry. Steel workers have long been working in shifts, high temperatures, noise, highly stressed, and first-line environments. These occupational related factors have an impact on the health of steel workers. At present, the existing hypertension risk scoring models do not include occupational related factors, so they are not applicable to the risk score of hypertension in steel workers. It is necessary to establish a risk scoring model for hypertension in steel workers. In this study, the learning vector quantization (LVQ) neural network algorithm and the Fisher-SVM coupling algorithm are applied to estimate the hypertension risk of steel workers, and the microscopic laws of the "tailing" phenomenon of the two

algorithms are analyzed by means of graphics analysis, which can describe the influence trend of sample size change in different intervals on the classification effect. The results show that the classification accuracy of the algorithm depends on the size of the sample space. When the sample size $n \leq 30 * (k + 1)$, the Fisher-SVM coupling intelligent algorithm is more applicable.

FRAMEWORK

This paper proposes a risk prediction model for dyslipidemia based on RNN and LSTM as shown in Fig.2.

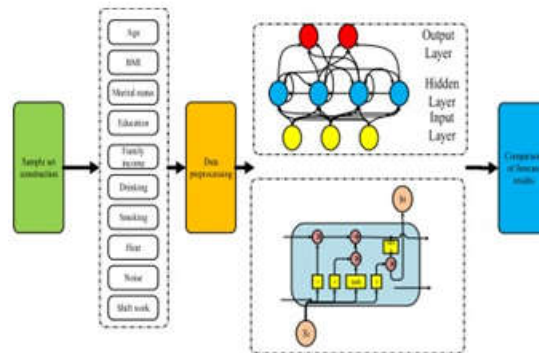

Figure.2: Proposed model

Dyslipidemia is a blood clot disease which accumulates cholesterol in human body or at heart side and this accumulation may cause heart attack if not identified on time and to predict such disease author is using deep learning algorithms such as RNN (Recurrent Neural Network) and LSTM (Long Short Term Memory). Author using steel workers dataset to train above two algorithms and then compare accuracy between those two algorithms.

ALGORITHM:

RNN (Recurrent Neural Network):

A recurrent neural network (RNN) is a type of artificial neural network which uses sequential data or time series data. These deep learning algorithms are commonly used for ordinal or temporal problems, such as language translation, natural language processing (nlp), speech recognition, and image captioning; they are incorporated into popular applications such as Siri, voice search, and Google Translate. Like feed forward and convolutional neural networks (CNNs), recurrent neural networks utilize training data to learn. They are distinguished by their “memory” as they take information from prior inputs to influence the current input and output. While traditional deep neural networks assume that inputs and outputs are independent of each other, the output of recurrent neural networks depend on the prior elements within the sequence. While future events would also be helpful in determining the output of a given sequence, unidirectional recurrent neural networks cannot account for these events in their predictions.

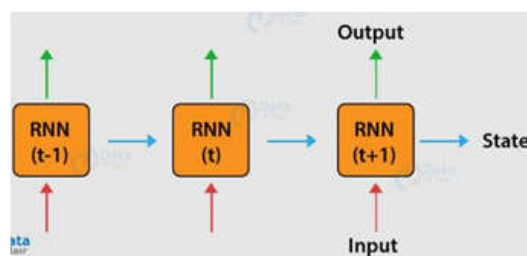

Figure.3: RNN model LSTM (Long Short Term Memory):

Long Short Term Memory is a kind of recurrent neural network. In RNN output from the last step is fed as input in the current step. LSTM was designed by Hochreiter & Schmidhuber. It tackled the problem of long-term dependencies of RNN in which the RNN cannot predict the word stored in the long-term memory but can give more accurate predictions from the recent information. As the gap length increases RNN does not give an efficient performance. LSTM can by default retain the information for a long period of time. It is used for processing, predicting, and classifying on the basis of time-series data. Structure of LSTM: LSTM has a chain structure that contains four neural networks and different memory blocks called cells.

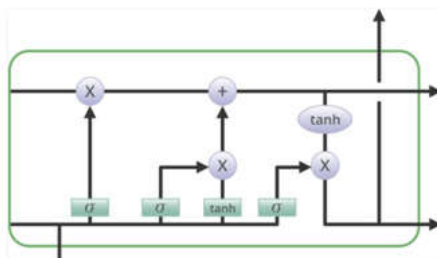

Figure.4: LSTM model

EXPERIMENTAL RESULTS.

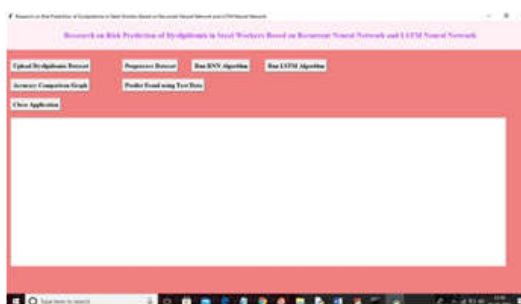

Figure.5: Home screen



Figure.6: dataset uploading

In above screen displaying few rows from dataset and this dataset contains some string values and deep learning only handle numeric values so we need to preprocess above dataset to remove or replace string values with numeric values.

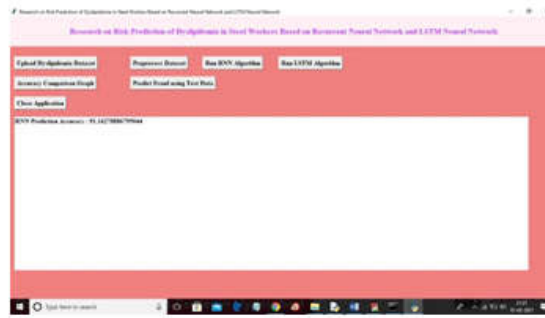

Figure.7: RNN algorithm

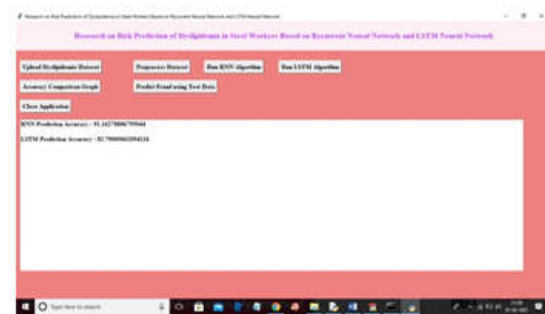

Figure.8: LSTM algorithm



Figure.9: Disease prediction screen

In above screen for some records application predicted Dyslipidaemia disease and for some records no disease detected.

CONCLUSION

A risk prediction model for dyslipidemia in steel workers was developed using RNN and LSTM networks in this paper. A survey of certain steel workers' long-term living habits and working environment was done, and ten main factors impacting dyslipidemia were extracted. To forecast the risk of dyslipidemia in steel workers, two prediction networks, RNN and LSTM, were developed. The prediction impact of LSTM is substantially superior than that of typical RNN networks, with an accuracy of more than 95%, according to experimental results.

FUTURE SCOPE:

The finding of possible illness risks and trends, which plays a significant role in disease prevention, intervention, and treatment, is referred to as disease risk prediction. The ideal goal of disease risk prediction in medicine is to identify prospective illness risks and trends before clinicians detect diseases, so that appropriate steps can be taken to prevent and intervene diseases. The findings in this research can help anticipate the risk

of dyslipidemia in steelworkers, give a scientific foundation for steelworker health protection, and broaden the breadth of deep learning theory's use in medicine. However, due to time constraints, we are unable to gather additional sample data, which may compromise the model's robustness. In the future, this content will be steadily improved.

REFERENCES

1. X. Xiao, S. Le Berre, D. G. Fobar, M. Burger, P.
2. J. Skrodzki, K. C. Hartig, A. T. Motta, and I. Jovanovic, ,,,Measurement of chlorine concentration on steel surfaces via fiber-optic laser-induced breakdown spectroscopy in double-pulse configuration, "" Spectrochimica Acta B, Atomic Spectrosc., vol. 141, pp. 44–52, Mar. 2018.
3. Z. Huang, L. Li, G. Ma, and L. C. Xu, ,,,Local information, and commanding heights: Decentralizing state-owned enterprises in China, "" Amer. Econ. Rev., vol. 107, no. 8, pp. 2455–2488, 2017.
4. Z. An, F. Shan, L. Yang, R. Shen, X. Gu, F. Zheng, and Y. Zhang, ,,,Unusual effect of temperature on direct fluorination of high temperature vulcanized silicone rubber and properties of the fluorinated surface layers, "" IEEE Trans. Dielectrics Electr. Insul., vol. 25, no. 1, pp. 190–198, Feb. 2018.
5. S. M. Kopeikin, ,,,Millisecond and binary pulsars as nature's frequency standards - II. The effects of low-frequency timing noise on residuals and measured parameters, "" Monthly Notices Roy. Astronomical Soc., vol. 305, no. 3, pp. 563–590, May 1999.
6. H. Tada, M.-A. Kawashiri, and M. Yamagishi, ,,,Comprehensive genotyping in dyslipidemia: Mendelian dyslipidemias caused by rare variants and mendelian randomization studies using common variants, "" J. Hum. Genet., vol. 62, no. 4, pp. 453–458, Jan. 2017.
7. K. N. Burns, S. K. Sayler, and R. L. Neitzel, ,,,Stress, health, noise exposures, and injuries among electronic waste recycling workers in ghana, "" J. Occupational Med. Toxicol., vol. 14, no. 1, Jan. 2019, pp. 77–80.
8. S. Hur, B. Min, K. Nam, E. Lee, and D. Ahn, ,,,Effect of dietary cholesterol and cholesterol oxides on blood cholesterol, lipids, and the development of atherosclerosis in rabbits, "" Int. J. Mol. Sci., vol. 14, no. 6, pp. 12593–12606, Jun. 2013.
9. P. Schulam and S. Saria, ,,,A framework for individualizing predictions of disease trajectories by exploiting multi-resolution structure, "" in Proc. Adv. Neural Inf. Process. Syst., 2015, pp. 1145–1170.
10. J.-H. Wu, W. Wei, L. Zhang, J. Wang, R. Damasevicius, J. Li, H.-D. Wang, G.-L. Wang, X. Zhang, J.-X. Yuan, and M. Wozniak, ,,,Risk assessment of hypertension in steel workers based on LVQ and Fisher-SVM deep excavation, "" IEEE Access, vol. 7, pp. 23109–23119, 2019.
11. N. An, H. Ding, and J. Yang, ,,,Deep ensemble learning for Alzheimers disease classification, "" Mach. Learn., vol. 5, pp. 583–590, May 2019.